

DESIGN NOTES

250kHz, 1mA I_Q Constant Frequency Switcher Tames Portable Systems Power – Design Note 108

Bob Essaff

DC-to-DC power conversion remains one of the toughest tasks for portable system designers. Dealing with various battery technologies and output voltage requirements dictate the need for creative circuit solutions. The two circuits discussed are tailored for operation from a single lithium-ion (Li-Ion) cell. These new batteries are finding widespread use due to their high energy storage capabilities. The first circuit has a 3.3V output and the second circuit has both 5V and -5V outputs for applications requiring dual supplies.

At the heart of each circuit is the LT[®]1373 current mode switching regulator. Guaranteed to operate down to 2.7V, this part allows the full energy storage capacity of a single Li-Ion battery to be used. The LT1373 draws only 1mA of quiescent current for high efficiency at light loads and has a low resistance 1.5A switch for good efficiency at higher loads. Switching at 250kHz saves space by reducing the size of the magnetics, and the fixed-frequency switching also reduces the noise spectrum generated. To avoid sensitive system frequencies the part can be externally synchronized to a specific frequency from 300kHz to 360kHz. The LT1373 can also be shut down where it draws only 12 μ A supply current.

3.3V SEPIC Converter

Generating a 3.3V output from a single Li-Ion cell is not straight forward because at full charge the battery voltage

is above the output voltage and when discharged, the battery voltage is below the output voltage. A conventional buck or boost regulator topology will not work. The circuit in Figure 1 uses the SEPIC (single-ended primary inductance converter) topology which allows the input voltage to be higher or lower than the output voltage. The circuit's two inductors, L1A and L1B, are actually two identical windings on the same inductor core, though two individual inductors can be used. The topology is essentially identical to a 1:1 transformer-flyback circuit except for the addition of capacitor C2 which forces identical AC voltages across both windings. This capacitor performs three tasks. First, it eliminates the power loss and spikes created by flyback-converter leakage inductance. Secondly, it forces the input current to be a triangular waveform riding on top of a DC component instead of forming a large amplitude square wave. Finally, it eliminates the voltage spike across the output diode when the switch turns on. Another feature of the SEPIC topology is that, unlike a typical boost converter, there is no DC path from the input to the output. This means that when the LT1373 is shut down, the load is completely disconnected from the input power source. Figure 2 shows that the 3.3V SEPIC converter maintains reasonable efficiency over two decades of output load current even though 3.3V circuits typically have low efficiency due to catch diode losses.

LT, LTC and LT are registered trademarks of Linear Technology Corporation.

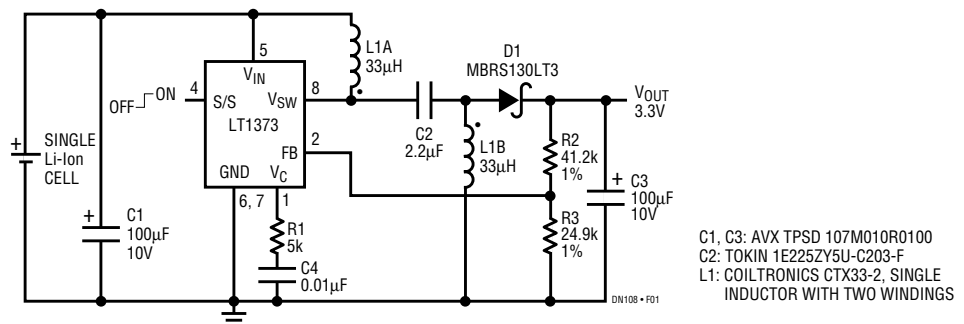

Figure 1. Single Li-Ion Cell to 3.3V SEPIC Converter

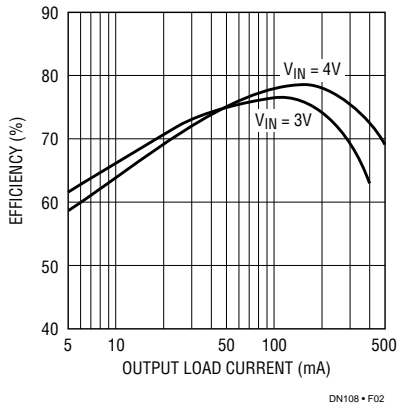

Figure 2. 3.3V Efficiency

Dual Output Converter

Many portable systems still require a negative bias voltage to operate interface or other circuitry, where the voltage accuracy is not critical. Using a single inductor, the circuit in Figure 3 generates a regulated 5V output and a quasi-regulated -5V output for such applications. The circuit first converts a single Li-Ion cell input voltage to a well-regulated 5V output. It then takes advantage of the switching waveform on the V_{SW} pin to generate the -5V output in a charge pump fashion. The voltage on the V_{SW} pin is 5V plus $D1$'s forward voltage when V_{SW} is high. At this time, $C3$ charges to the V_{SW} voltage minus $D2$'s forward voltage or about 5V. When the V_{SW} pin goes low, the minus side of $C3$ goes to -5V which turns on $D3$ and charges $C5$ to

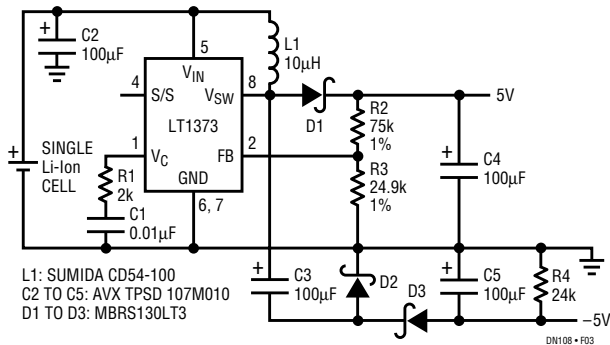

Figure 3. Single Li-Ion to $\pm 5V$

-5V. This generates a -5V supply which is only quasi-regulated due to diode drop and switch saturation losses. Figure 4 shows the regulation of the negative output for various positive output load currents. As shown in Figure 5, the dual output converter has high efficiency over two decades of load current.

For more information, please consult the LT1373 data sheet. For parts similar to the LT1373 with higher switching frequencies (500kHz and 1MHz), consult the LT1372/LT1377 data sheet.

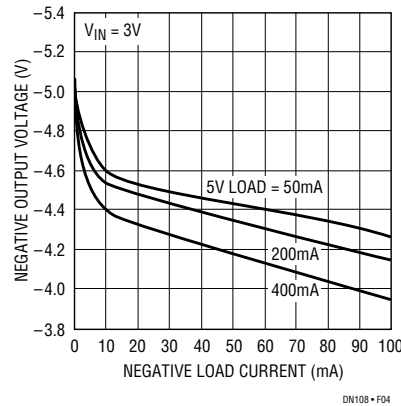

Figure 4. -5V Regulation

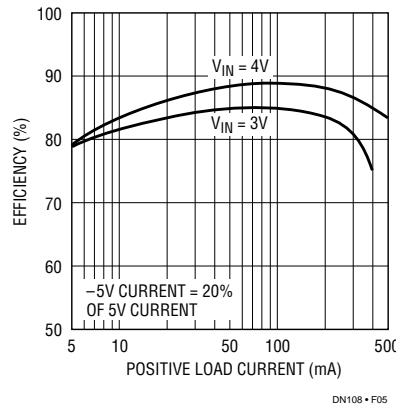

Figure 5. Dual Output Efficiency

For literature on our Switching Regulators, call **1-800-4-LINEAR**. For applications help, call (408) 432-1900, Ext. 361